

A Critical Study & Analysis of Assimilation Development of Tractors and Trolleys with Safety as a Major Consent

Samir Telang¹, Arvind Chel²,

¹Research Scholar, Dept. of Mechanical Engg, MGM's Jawaharlal Nehru Engineering College, Aurangabad-431003, Maharashtra, India Email ID : samirtelang@rediffmail.com

² Dept. of Mechanical Engineering, MGM's Jawaharlal Nehru Engineering College, Aurangabad-431003, Maharashtra, India. Email: achel@mgmu.ac.in

Abstract:

Tractor safety is one of the important concern. This paper includes Traction performance of 73 models of Indian tractors under three size groups viz. small (< 18 kW), medium (18–26 kW) and large (> 26 kW) have been studied and analysed based on tractor test results. The result of the analysis reveals that the values of traction co-efficient (ratio of drawbar pull to drive wheel load) are more under un-ballasted condition than that under ballasted condition for all models of tractor under study. Traction coefficient varies among the different models of tractors. Similarly, the tractive efficiency (drawbar power to PTO power ratio) are also found to vary among the different models of tractor irrespective of their sizes. These variations, which were observed even on the performance on concrete test terrain, might be the reason of improper matching of wheel load (ballast), power and tyre size. Operation tasks of tractors and trolleys in agriculture have changed considerably over the last decade. Today on the roads of India and in the States Maharashtra tractors whose speed exceeds 60 km/h, even when fully loaded, which raises important issue of the effective stopping i.e. the Construction, working and quality of the braking system. Tractor trailers must correspond to the tractors with respect to size and weight, but must be capable of moving at speeds of towing vehicle. Their braking must be synchronized with the tractor and must not affect the deterioration of the operation quality of tractor-trailer combination. Also important is their good maintenance to avoid problems with the braking of the towing vehicle. In order to address these issues, revised braking requirements about safety and controls to all agricultural tractors and their trailers (both new and existing). They will also apply to equipment such as trailers, slurry tankers, fertilizer, spreaders, grain chaser bins and so on

Keywords: Traction, Draw Bar Pull, tractors, trolleys, brake system, Safety Requirement

I. INTRODUCTION

The basic technology of agricultural machines has changed little over the last decade. Though in modern combine harvesters and planters may do a better job than their Predecessors, the combine of today cuts, thresh, and separates grain in essentially the same way earlier versions had done. However, technology is changing rapidly the way that humans operate the machines, as computer monitoring systems, GPS locators, and self –steer programs allow the most advanced tractors and implements to be more precise and less wasteful in the use of fuel, seed, or fertilizer. In the foreseeable future, some agricultural machines may be made capable of driving themselves, using GPS maps and electronic sensors. There is a tendency worldwide to improve tractor's transporting performance by increasing tractor speed. Faster, bigger, more powerful and more manoeuvrable machines are capable of developing ever higher speeds. Only the future will show whether the achievement of 60 km/h speeds signals an upper limit. Nevertheless, the increase of the agricultural vehicles' speed requires efficient braking system that should enable agricultural vehicles to keep the pace with the other fast vehicles participant in road traffic, taking into account traffic safety. Braking technology for the mega -machines of today and tomorrow needs to be equally efficient, low-maintenance, convenient and economical. Highly effective, oil – cooled multi servo disk brakes guarantee a solid, reliable braking performance.



TRACTOR & TROLLEY COMBINATION

II. key feature:

The standards associated with tractors are much more complicated than one outside of the standard's profession might expect. Tractor standards include three basic types of standards: **safety, performance and interoperability**. There are seven different major Standard

Development Organizations (SDOs) for the agricultural tractor industry: government of India, central farm machinery training & testing institute min. of agri., (dept. of agri. and co-opn.) tractor nagar, p.o. budni (m.p.) 466 445, the Organization for Economic Co-operation and Development (OECD), International Organization for Standardization (ISO), International Electrotechnical Commission (IEC), Society of Automotive Engineers (SAE) International, American Society of Agricultural and Biological Engineers (ASABE), Association of Equipment Manufacturers specifies the performance requirements for the braking systems of wheeled agricultural tractors with a maximum speed of up to 40 km/h (categories T1, T2 and T3). This directive was last modified in 1996. When the directive came under revision, tractors faster than 40 km/h (Category T5) and trailers & interchangeable towed machinery (category R&S) have come into the scope. Until a compromise has been found between Indian Commission/Member Industry categories, T5 and R&S vehicles fall under national type approval for braking. Braking on self-propelled agricultural machinery is also handled by national approvals.

Vehicles add requirements and expand the scope to cover tractors, trailers, and towed equipment up to 60 km/h and above. Also in development is ISO 12933 Agricultural tractors- Safety and performance requirements for braking. The historical national differences within the ARAI, especially concerning trailer braking, require a lot of effort because the process of harmonization is complicated Braking System Test Procedures and Braking Performance Criteria for Agricultural Field Equipment for braking requirements

III. Range & Scope:

The scope of this standard includes both tractors and agricultural equipment. For Indian designer of tractors marketed in Asia, the minimum park brake performance requirement in this standard is particularly noteworthy. To paraphrase, the parking brake needs to hold the equivalent of 2.5 times the maximum weight rating for the tractor on an 18% slope. This is more rigorous than the European equivalent of the maximum weight rating of a tractor on an 18% slope. Again, this difference can be traced back to the cultural practice and requirement for the use of chocks in India with no like requirement. A trailer may weigh up to 1.5 times the weight of the tractor before trailer brakes are required, hence the parking brake requirement.

NEWBRAKING LEGISLATION:As agricultural tractor size and speeds have increased during recent years, heavier loads are transported on public roads at higher speeds. Due to the increased speed of tractors, their braking system has been enhanced. In view of the road safety, the braking systems of agricultural vehicles must meet a number of requirements for, among other things, braking efficiency, the follow-up action



A typical Trolley & its axle visual

during slow braking, and a high speed of action during sudden braking. The operation of a high speed modern agricultural tractor with high-efficiency brakes coupled with a low braking efficiency trailer will lead to the accelerated wear and premature damage of the trailer's braking system and, on the other hand, cause overloading, rapid wear and possible damage of the tractor's braking system.

IV. Critical Study & Analysis:

Tractors that travel below 40km/h must have a braking efficiency of 25%. If a tractor is to travel faster than 40km/h it must comply. The regulations set out that the vehicles must have service, secondary and parking brakes and a braking efficiency of at least 45%. When a trailer is being used further complications are added. The regulations state that the trailer brakes must be able to be applied independently should the tractor's brakes fail. A further stipulation is that the trailer's brakes must be applied automatically if the tractor and trailer become decoupled. The Directive does not stipulate that air-brakes are necessary; however most of the aforementioned requirements can be met by use of air brakes. Most tractor and trailer combinations do not comply with this regulation, confirmation can be provided by the manufacturer.

Tractor-trailer operation at 50km/h increases the energy dissipation requirement placed upon the vehicle braking systems by over 140% (an approx. 2.5 times increase) [1]. Whilst modern tractor systems have usually been engineered to accommodate this increase, trailer braking systems currently in -service frequently have not: a situation accentuated by the fact that agricultural trailers are usually expected to have a frontline service life of 15-20 years plus. A trailer can easily outlive two or more generations of tractor, but only if the running gear and braking systems are adequately specified in the first instance. The trailer braking system is undersized, the initial consequence is accelerated wear and premature failure of the trailer braking system, followed by overloading, rapid wear and eventual failure of tractor braking system. This has become an increasing problem within the EU in recently ears, as demonstrated by the proportion of tractor braking system failures during vehicle warranty periods arising from these regions

[2].Disproportionate effect of increasing speed upon vehicle kinetic energy

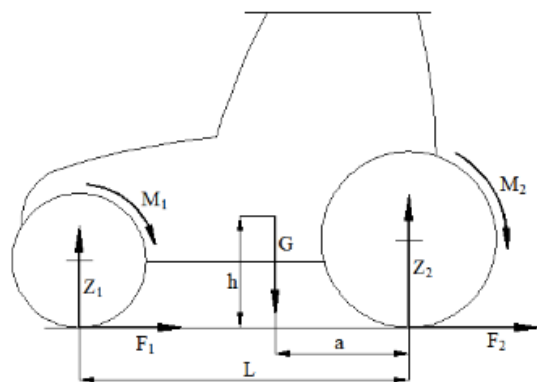

Diagram of forces and moments acting on a 4x4 tractor
- braking applied on all wheels

2.1 Revised Requirements for Agricultural Tractors A summary of the minimum tractor braking performance requirements expressed as percentage efficiencies (i.e. braking effort as a percentage of the tractor's Design Gross Vehicle Weight) are included below. These will apply to both new and existing agricultural tractors .

Revised Agricultural Tractor Braking Standards Applicable as per ISO. Minimum Braking Performance Requirements for Agricultural Tractors Speed rating less than or equal to 40km/h Service Brake (25%) Parking Brake (16%) Service Brake (45%) Emergency Brake(22.5%) Parking Brake (16%)

2.2 Revised Requirements for Agricultural Trailers A summary of the minimum trailer braking performance requirements, once again expressed as percentage efficiencies, are included in Table 2 below. Note that the figure quoted for the service brake performance is based on the weight transmitted to the road surface by the trailer axle(s) fitted with brakes, whereas the breakaway and parking brake performances quoted are based on the Design Gross Vehicle Weight (DGWV) of the trailer. Agricultural Trailer Braking Standards Applicable as per ISO norms & Minimum Braking Performance Requirements for Agricultural Trailers Trailers with a speed rating less than or equal to 40km/h and a Design Gross Vehicle Weight (DGWV) exceeding 5,000kg. Trailers with a speed rating greater than 40km/h and a Design Gross Vehicle Weight (DGWV) exceeding 3,500kg. Service Brake (25%) Breakaway Brake (13.5%) Parking Brake (16%) Service Brake (45%) Breakaway Brake (13.5%) Parking Brake (16%) Furthermore all agricultural trailers which are manufactured from 1st January 2018 and are capable by design of being drawn at a speed exceeding 40km/h must be equipped with: pneumatic braking systems (including load sensing functionality which matches the service brake effort to the weight of the load being carried); and those capable of being drawn at a speed exceeding 60km/h must also be equipped with antilock braking systems (ABS).

A breakaway brake capable of automatically stopping them should they become detached from the tractor while in motion. However agricultural trailers manufactured (provided they are incapable by design of being drawn at a speed exceeding 40km/h) may alternatively be fitted with a secondary coupling consisting of a chain or wire rope. Agricultural trailers and interchangeable towed equipment manufactured, which are capable by design of being drawn at a speed exceeding 40km/h and which are not fitted with a breakaway brake have until to achieve compliance.

Conclusion:

One can be killed or seriously injured if he is involved in a tractor accident. Almost all tractor accidents are preventable. By practicing safe work habits, use of specified equipments, Use & Understand the load conditions and according to use of Specific Tractor after follows scientific driving one can easily prevent tragedy on the job. Take control of his own safety by following the practices outlined in this Research Paper. This all information may Useful to keep work experience safe particularly in farms, remote areas, villages, Rural area.

Selected References and Resources Publications

A Guide to Agricultural Rollover Protective Structures. A publication of the National Farm Medicine Center, Marshfield, WI.

(Available at http://www.marshfieldclinic.org/nfmc/default.aspx?page=nfmc_rops_guide)

Agriculture at Risk: A Report to the Nation. Merchant J, Kross B, Donham K, Pratt D (eds).

The National Coalition for Agricultural Safety and Health, Iowa City, IA, 1989.

National Committee for Childhood Agricultural Injury Prevention. Children and Agriculture: Opportunities for Safety and Health. Marshfield Clinic, Marshfield, WI, 1996.

Donham K, Osterberg D, Meyers M, Lehtola C, Rautiainen R, Loveless L, Bedford L (eds).

Tractor Risk Abatement and Control: The Policy Conference. Iowa's Center for Agricultural Safety and Health, and The Great Plains Center for Agricultural Health, The University of Iowa. Iowa City, IA, 1997.

(Available at <http://www.public-health.uiowa.edu/ICASH/TRACreport.pdf>) [link not active]

Jenkins S, Marlenga B. Introduction to the W.K. Kellogg Agricultural Safety and Health (ASH) Initiative, J Agromedicine 1998; 5(2):3-7.

Lee B, Marlenga B (eds). Professional Resource Manual: North American Guidelines for Children's Agricultural Tasks. Marshfield Clinic, Marshfield, WI, 1999.

Meyers M, et al (eds). Papers and Proceedings of the Surgeon General's Conference on Agricultural Safety and Health. DHHS (NIOSH) # 92-105. National Institute for Occupational Safety and Health. Cincinnati, OH, 1992.

Myers J, Snyder K. Roll-over Protective Structures Use and the Cost of Retrofitting Tractors in the United States, 1993. J Agr Saf Health 1995; 1(3): 185-197.

Pana-Cryan R, Myers M. Prevention Effectiveness of Rollover Protective Structures -- Part III: Economic Analysis. J Agr Saf Health 2000; 6(1):57-70.

Reynolds S, Groves W. Effectiveness of Roll-Over Protective Structures in Reducing Farm Tractor Fatalities. Am Prev Med 2000; 18(4S):63-69.

Web/Videos

Cyber-Tractor

<http://safety.cfans.umn.edu/tractor/purpose.htm> [link not active]

Institute of Agricultural Rural and Environmental Health.

Tractor Rollovers and Run Overs: Can You Prevent One On Your Farm?

<http://www.iareh.usask.ca/rhep/teaching/trr.htm>

Kentucky Community Partners for Healthy Farming ROPS Project: A Program of Materials and Activities to Preserve Farmers' Health, Way of Life and Money, 2000.

<http://www.nasdonline.org/docs/d000901-d001000/d000997/9.html>

National Agricultural Safety Database There are about 20 tractor safety videos listed in the National Agricultural Safety Database.

<http://www.nasdonline.org>